

# Zebra *Xi*II-Series Printer Quick Reference Guide



---

# Contents

Media and Ribbon Loading .....	67
Media Loading .....	67
Ribbon Loading .....	70
Operator Controls .....	72
Front Panel Keys .....	72
Front Panel Lights .....	72
Calibration .....	74
Configuration .....	75
Preventive Maintenance .....	77
Printhead and Platen Roller Cleaning Procedure .....	77
Adjustments .....	78
Toggle Positioning .....	78
Printhead Pressure Adjustment .....	78
Media Sensor Position Adjustments .....	78

## Introduction

This Zebra *XiII*-Series Printer Quick Reference Guide contains basic information on how to install and operate the printer as well as some simple adjustments that can be performed by the operator. It is not comprehensive.

Additional information covering the Zebra *XiII*-Series printers is available from your distributor:

- User's guide
- *ZPL II Programming Guide*
- Multi-language safety data guide
- Maintenance manual

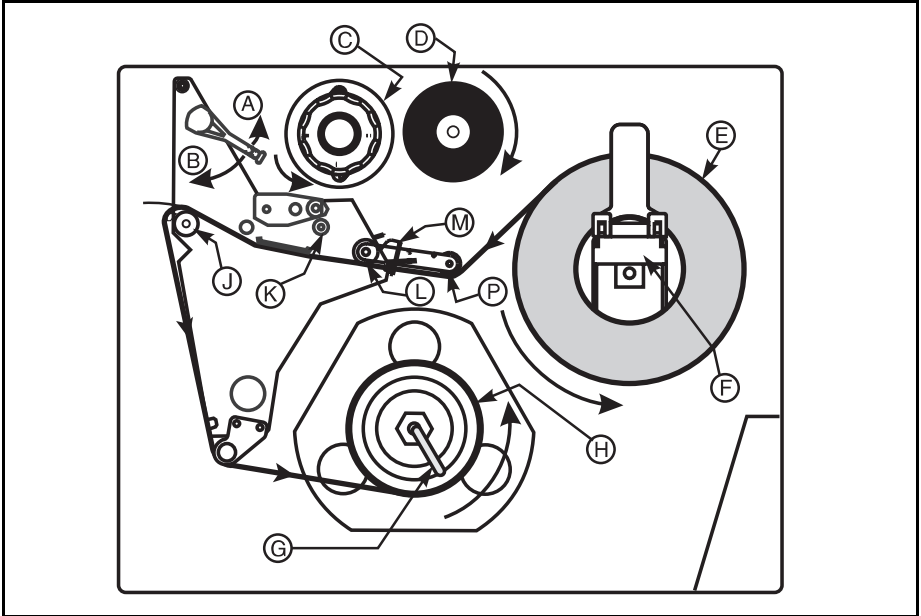

Figure 1. Media Loading

## Media Loading

### Roll Media Loading in Tear-Off Mode (Fig. 2-A)

1. Place the Media Roll (Fig. 1-E) on the Media Hanger (Fig. 1-F) or optional Supply Spindle.
2. Open the printhead by moving the lever located on the Upper Printhead Assembly to the open (Fig. 1-A) position.
3. Loosen the Media Guide (Fig. 1-M) Thumb-screw and position the Guide as far out from the printer frame as possible.
4. Thread the media under the Dancer Arm Assembly (Fig. 1-P), under the Lower Roller (Fig. 1-L), between the upper media guide plate and main media guide, under the printhead, and over the Platen (Fig. 1-J).
5. Adjust the Media Guide (Fig. 1-M) position until it just touches the outer edge of the media without causing it to buckle, make sure it is parallel to the edge of the media, then tighten the thumbscrew.
6. Close the printhead by moving the lever located on the Upper Printhead Assembly to the closed (Fig. 1-B) position.
7. **IMPORTANT:** Perform the Media Sensor Position Adjustments found on page 78.



## **Peel-Off Mode (Fig. 2-B)**

**Note:** For best results, install the printer on a level surface. This is especially helpful with wider printers using wide media. If the surface is not level, the media may “telescope” off of the Rewind Spindle, causing unsatisfactory results.

1. Remove the Rewind Plate if one is present and store it on the two mounting screws on the inside of the front panel. Align the notch in the bracket so that the Take Label Sensor can sense a peeled label.
2. Load media according to the directions for Tear-Off Mode. When loading the media, allow about one yard of media to extend past the Tear-Off bar. If using label stock, remove all labels from this portion of the media to create a leader.
3. Remove the Hook (Fig. 1-G) from the Take-Up Spindle Shaft (Fig. 1-H). If you are using a core, remove all tape from the core and slide it onto the Rewind Spindle until it is flush against the guide plate.
4. Wind the backing 1-2 times around the Media Take-Up Spindle and reinstall the Hook. Make sure that the media backing is against the Backing Guide Plate. (With some types of media, especially tag stock, you may need to tape the end of the media to the core if it will not otherwise tighten onto the core. **DO NOT** tape the label stock unless absolutely necessary.)

**Note:** Before closing the Printhead Open Lever, make sure that throughout the media pathway (1) the media is positioned against the inside guides, and the outer guide and Media Supply Guide barely touch the media, (2) the media is taut, and (3) the media is parallel with itself and with the pathway when wound on the Rewind Spindle/core.

5. After all of the above steps have been completed, close the Printhead Open Lever to lock the media in place. If not aligned correctly, the material may not rewind properly on the Rewind Spindle/core that may, in turn, affect media movement and/or printing.

## **Rewind Mode (Fig. 2-C and 2-D)**

**Note:** For best results, install the printer on a level surface. This is especially helpful with wider printers using wide media. If the surface is not level, the media may “telescope” off of the Rewind Spindle, causing unsatisfactory results.

1. Remove the Media Rewind Plate (Fig. 2-F) from its storage location in front of the print mechanism inside the media compartment.
2. Invert the Rewind Plate so that the lip on the attached Hook Plate (Fig. 2-G) points down.
3. Insert the Hook Plate lip into the lower opening in the Side Plate and slide the Rewind Plate in so that it stops against the Main Frame.
4. (Only for printers with Cutter/Rewind Option, Fig. 2-D). Insert the two small tabs on the Rewind Plate into the corresponding slots in the Cutter Support Bracket. The Rewind Plate should “spring” into the proper position.
5. Load media according to the directions for Tear-Off Mode. When loading the media, allow about one yard of media to extend past the Tear-Off bar. If using label stock, remove all labels from this portion of the media to create a leader.
6. Remove the Hook (Fig. 1-G) from the Take-Up Spindle Shaft (Fig. 1-H). If you are using a core, remove all tape from the core and slide it onto the Rewind Spindle until it is flush against the guide plate.
7. Route the media as shown in Figures 1 and 2 and wind it 1-2 times around either (1) the Media Take-Up Spindle and reinstall the Hook, or (2) a 3" (76.2 mm) core. (With some types of media, especially tag stock, you may need to tape the end of the media to the core if it will not otherwise tighten onto the core. **DO NOT** tape the label stock unless absolutely necessary.)

**Note:** Before closing the Printhead Open Lever, make sure that throughout the media pathway (1) the media is positioned against the inside guides, and the outer guide and Media Supply Guide barely touch the media, (2) the media is taut, and (3) the media is parallel with itself and with the pathway when wound on the Rewind Spindle/core.

8. After all of the above steps have been completed, close the Printhead Open Lever to lock the media in place. If not aligned correctly, the

material may not rewind properly on the Rewind Spindle/core that may, in turn, affect media movement and/or printing.

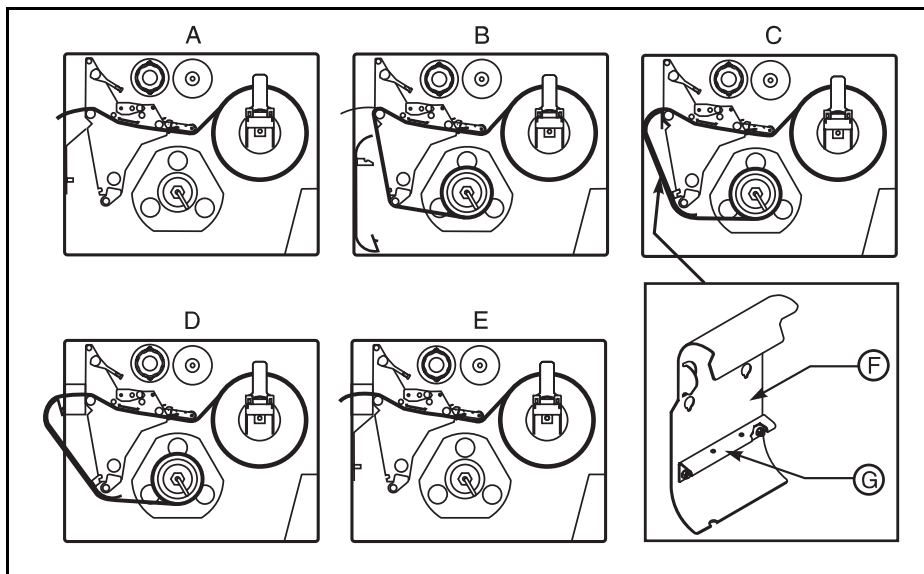

Figure 2. Roll Media Loading

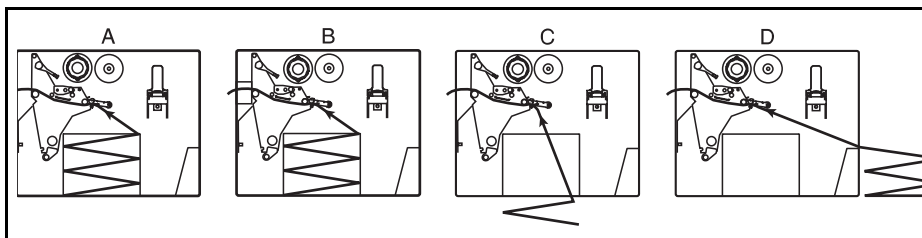

Figure 3. Fanfold Media Loading

### **Cutter Mode (Fig. 2-E)**

1. Load media according to the directions above for Tear-Off Mode, except feed the media through the cutter module as shown in Fig. 2-E.
2. Make sure that the Cutter Option is available and installed on the printer and that the Cutter Mode is configured using the front panel keys and display screen.

### **Fanfold Media Loading (Fig. 3)**

Fanfold media can be placed in the bottom of the media compartment, in the Fanfold Supply Bin, or outside of the printer with access through the bottom or the rear.

Adjust the Media Guide (Fig. 1-M) Thumbscrew to keep the media from drifting. Make sure it is parallel to the edge of the media.

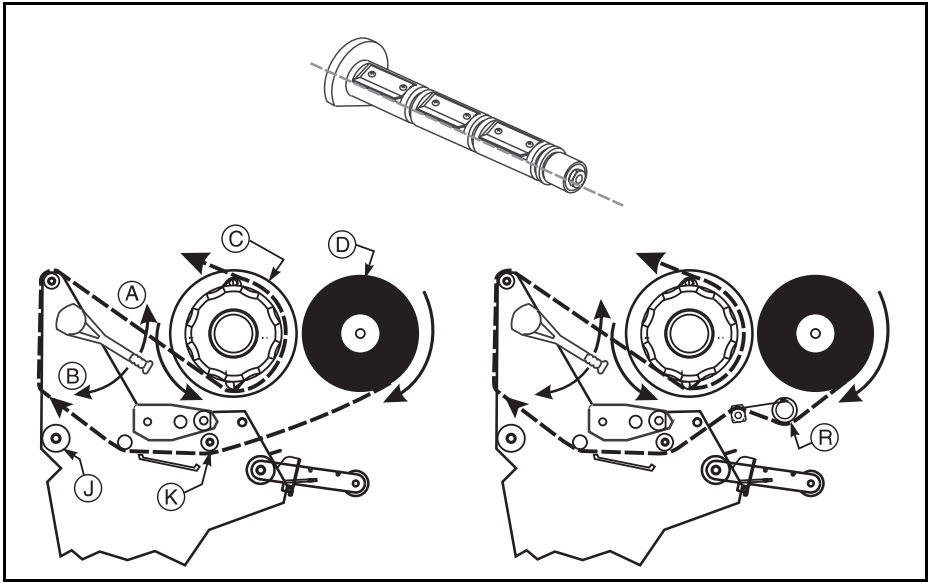
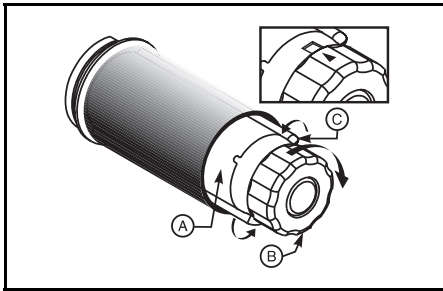

Figure 4. Ribbon Loading

## Ribbon Loading

When loading ribbon, make sure that the ribbon core is pushed up against the stop on the Ribbon Supply Spindle (Fig. 1-D). *Do not use ribbon narrower than the media.*

1. Align the segments of the Ribbon Supply Spindle (Fig. 4).
2. Place the Ribbon Roll on the Ribbon Supply Spindle (D).
3. Make a leader for your ribbon. Tear off a strip of media (labels and backing) about 15-30 cm (6-12") long. Peel off a label from this strip. Apply half of this label to the end of the strip and the other half to the end of the ribbon. This acts as a ribbon leader.
4. Open (A) the printhead and thread the leader and attached ribbon through the print mechanism, under the Upper Roller (Fig. 4-K), and past the Platen (Fig. 4-J). Note: For the 170XiII and 220XiII, thread the leader first through the Dancer Roller Assembly (Fig. 4-R).
5. Before wrapping the ribbon around the Ribbon Take-Up Spindle, ensure that the arrow on the knob aligns with the indented notch (see inset, Fig. 5).
6. Place the ribbon (with leader, if used) around the Ribbon Take-Up Spindle (Fig. 4-C) and wind counterclockwise for several turns.
7. Close (Fig. 4-B) the printhead.



**Figure 5. Removing Used Ribbon**

## Removing Used Ribbon

Refer to Figure 5.





1. Break the ribbon close to the Ribbon Take-Up Spindle (A).
2. While holding the Ribbon Take-Up Spindle, turn the knob (B) clockwise until it stops. This will cause the Ribbon Release Bars to pivot down (C), easing the spindle's "grip" on the wound ribbon
3. Slide the ribbon off of the Ribbon Take-Up Spindle. Once the used ribbon has been removed, ensure that the arrow on the knob aligns with the indented notch in the Ribbon Take-Up Spindle (see inset).
4. Remove the empty core from the Ribbon Supply Spindle.



# Operator Controls

## Front Panel Keys

**Table 1. Front Panel Keys**

	Press to enter/exit Pause Mode.
	Feeds one blank label each time you press the key.
	(Active only in Pause Mode.) Press once to cancel printing of current label batch. To clear the entire buffer, press and hold until the Data light turns off.
	(Active only in Pause Mode.) Press once to recalibrate media and ribbon sensors for proper media length and to set media type (continuous or non-continuous).
 <p>These keys are used in the Configuration process.</p>	

## Front Panel Lights

Table 2 describes the operation of the front panel lights.



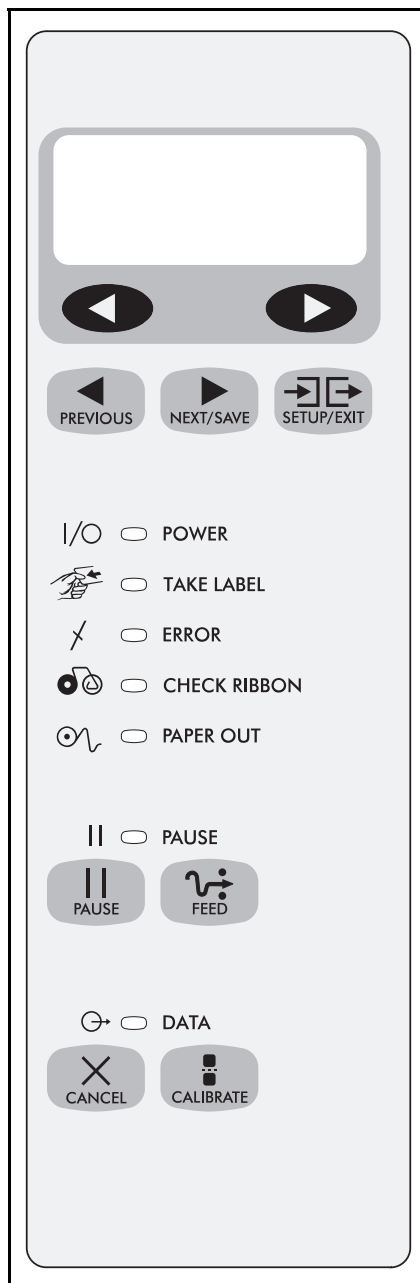



**Note:** If an operating condition which causes a light to be on constantly and one which causes the same light to flash occur at the same time, the light will flash.



**Figure 6. Front Panel**



**Table 2. Front Panel Lights (Continued)**

Light	Status	Indication
TAKE LABEL 	Off	Normal operation.
	Flashing	(Peel-Off Mode Only) Label is available. Printing is paused until the label is removed.
ERROR 	Off	Normal operation—no printer errors.
	Flashing	Printer error exists. Check the display screen for more information.
CHECK RIBBON 	Off	Normal operation—ribbon is properly loaded.
	On	No ribbon loaded (printer in Thermal Transfer Mode). Front panel displays error message.
PAPER OUT 	Off	Normal operation—media is properly loaded.
	On	No media is under the media sensor. Printing is paused, the display shows an error message, and the Pause light is on.
PAUSE 	Off	Normal operation.
	On	Printer has stopped all printing operations. Either  was pressed, a pause command was included in the label format, the Zebra On-Line Verifier detected an error, or a run-time error was detected.
DATA 	Off	Normal operation—no data being received or processed.
	On	Data processing or printing is taking place—no data is being received.
	Flashing	Printer is receiving data. Flashing slows when the printer cannot accept more data, but returns to normal once data is again being received.



---

# Calibration

After you have correctly installed the media and ribbon, turn the printer on. The printer will perform a power-on self test. When this is complete, the display screen will read “PRINTER READY”.

Perform the Calibration procedure below.

---

**IMPORTANT:** Perform the Calibration procedure when media and ribbon are first installed and whenever a different type of media or ribbon is installed.

---

During this procedure, the printer automatically determines continuous/non-continuous media, label length, media and ribbon sensor settings, and printing method (thermal transfer/direct thermal).

1. Press  .

2. Press  .

The printer feeds several labels.

3. Press  .

After you have completed the Calibration, you may set printer parameters for your application using the front panel display and the five keys directly below it.

The Configuration Procedure in Table 3 contains the information you will need to get your printer up and running, but it is not comprehensive. Refer to the user's guide for more information.

Enter the Configuration Mode by pressing



at the PRINTER READY display. Follow the procedure in Table 3. You may exit the

Configuration Mode at any time by pressing



(follow the instructions at the end of the table).

- An asterisk (\*) in the upper left-hand corner of the display indicates that you have changed this setting from what is currently stored in memory.
- To change a parameter, use the left and right black oval keys just below the display screen:









Increases value, answers “yes”, indicates “on”, or displays the next selection.













Decreases value, answers “no”, indicates “off”, or displays the previous selection.

**Table 3. Configuration Procedure**



1. Press:	2. Display Shows:	Action/Explanation:
—	PRINTER READY	Normal printer operation.
	DARKNESS	Press the oval keys to change the darkness of printing. CAUTION: Set the Darkness to the lowest setting that provides good print quality. Darkness set too high may cause ink smearing and/or it may burn through the ribbon.
To change the front panel display language (skip if the display is already in your preferred language):		
	LANGUAGE	Press the oval keys to change the language of the front panel display text.
	DARKNESS	Press the oval keys to change the darkness of printing. CAUTION: Set the Darkness to the lowest setting that provides good print quality. Darkness set too high may cause ink smearing and/or it may burn through the ribbon.
	TEAR OFF	Press the oval keys to change the position of the media over the tear bar after printing. Adjust this setting if labels are being torn in the wrong place.
	PRINT MODE	Press the oval keys to select Tear-Off, Peel-Off, Cutter, or Rewind Mode. Make sure you choose a mode that is available for your specific printer because some of these modes require special options.
	MEDIA TYPE	Press the oval keys to select continuous or non-continuous media type. Non-continuous: the printer automatically determines the label length by sensing the notch, gap, web, or black mark between labels. Continuous: you must include a label length instruction in your label format (^LLxxxx if you are using ZPL or ZPL II).

**Table 3. Configuration Procedure (Continued)**

	SENSOR TYPE	Press the oval keys to select web or mark sensing mode. If your media does not have black marks on the back, leave your printer at the default (web) setting.
	PRINT METHOD	Press the oval keys to select the method of printing you want to use: direct thermal (no ribbon) or thermal transfer (using thermal transfer media and ribbon).
	PRINT WIDTH	Press the oval keys to set the printer to a width that is close to your media, but AT LEAST as wide.
	MAXIMUM LENGTH	Press the oval keys to set the maximum print length. Select the value closest to but not less than the length of label you are using.
	LIST FONTS	Press the right oval key to print a list of available fonts.
	LIST BAR CODES	Press the right oval key to print a list of available bar codes.
	LIST IMAGES	Press the right oval key to print a list of available images.
	LIST FORMATS	Press the right oval key to print a list of all formats currently stored in the printer's DRAM, optional EPROM, or on an optional memory card.
	LIST SETUP	Press the right oval key to print a list of the current printer configuration settings.
	SAVE SETTINGS	<p>Press the oval keys to select:</p> <p>PERMANENT—saves the changes when the power is turned off</p> <p>TEMPORARY—saves the changes until changed again or until power is turned off</p> <p>CANCEL—cancels all changes since entering the Configuration Mode</p> <p>LOAD DEFAULTS—loads factory default values for all parameters. Note: Refer to the user's guide! This requires Calibration and resetting of the Head Resistance!</p> <p>LOAD LAST SAVE—loads values from the last permanent save.</p> <p>Press  to accept a selection.</p>
—	PRINTER READY	You have exited the Configuration Mode and you are now ready for normal printer operation.

# Preventive Maintenance

Perform the following cleaning activities according to the schedule below. Refer to Figure 7.

**Table 4. Cleaning Schedule**

Area (Refer to Fig. 7.)	Method	Interval
Printhead (A)	Solvent*	Direct Thermal Print Mode: After every roll of media (or 500 ft. of fanfold media) Thermal Transfer Print Mode: After every roll of ribbon.
Platen Roller (B)	Solvent*	
Media Sensor (Fig. 9 A and 10 A)	Air blow	
Media Path (Fig. 1)	Solvent*	
Ribbon Sensor (C)	Air blow	
Peel/Tear Bar (E)	Solvent*	As needed.
Label Available Sensor (D)	Air blow	Monthly.
Black-Mark Sensor (F)	Solvent*	Monthly.

\* The recommended solvent is 70% isopropyl alcohol.



## Printhead and Platen Roller Cleaning Procedure

Inconsistent print quality such as voids in the bar code or graphics may indicate a dirty printhead. For best results, perform the following cleaning procedure after each roll of ribbon.

You do NOT need to turn off the power for this procedure. If you turn off the power all data stored in the printer's temporary memory will be lost.

1. Open the printhead by moving the printhead lever to the open position.
2. Remove the media and ribbon from the print mechanism.
3. Moisten an applicator with Zebra Technologies Corporation-recommended solvent. Wipe the printhead (A) elements from end to end. (The printhead elements form the grayish/black strip just behind the chrome strip.) Allow a few seconds for the solvent to evaporate.
4. Rotate the Platen Roller (B) and clean thoroughly with solvent.

5. Brush/vacuum any paper lint and dust away from the rollers, the Media Sensor (Fig. 9 A and 10 A), the Black-Mark Sensor (F), and the Ribbon Sensors (C).
6. Reload ribbon and/or media as necessary. Close the printhead by moving the lever to the closed position. If you turned off the power before performing this procedure, turn it on again now. You may now continue printing.

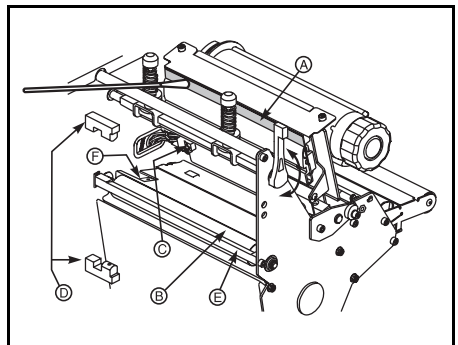

**Figure 7. Printhead Cleaning**

# Adjustments

## Toggle Positioning

Position the toggle(s) to provide even pressure on the media by sliding them to the desired location. If you are using narrow media and your printer has two toggles, you may position one toggle over the center of the media and slide the other toggle out of the way (decrease the pressure on the unused toggle).

## Printhead Pressure Adjustment

Adjust the printhead pressure if printing is too light on one side or if thick media is used. Refer to Figure 8.

1. Lower the darkness setting and print some labels.
2. Loosen the Upper Locking Nuts (A).
3. Increase or decrease pressure using the Adjusting Nuts (B) until the left and right edges of the printed area are equally dark.
4. Increase darkness to desired level.
5. Tighten Locking Nuts.

**Note:** Maximize printhead life by using the lowest pressure that provides the desired print quality.

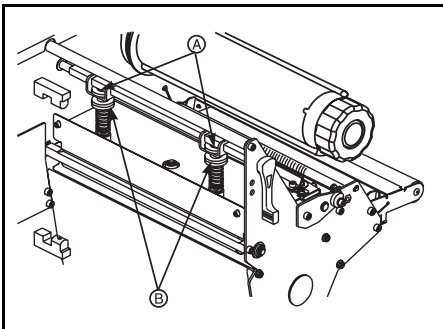

Figure 8. Printhead Pressure Adjustment

## Media Sensor Position Adjustments

The Media Sensor must be positioned so that it can detect the “web” between labels or a hole or notch in the media.

The factory-set position should be sufficient for most applications. If not, perform the appropriate adjustments.

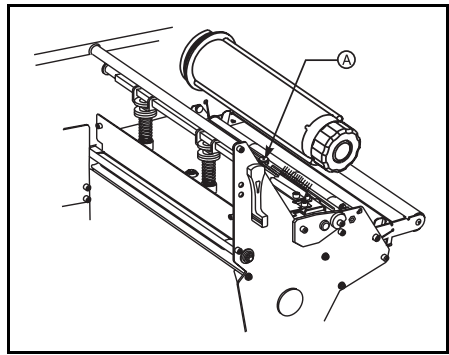

Figure 9. Upper Media Sensor

## Upper Media Sensor Adjustment

**To adjust for the inside half of the media:**

1. Remove the ribbon. Locate the Upper Media Sensor (Fig. 9-A).
2. Loosen the Phillips head screw.
3. Slide the upper sensor along the slot until it is directly above the web, notch, or hole in the media.
4. Tighten the screw.

**To adjust for the outside half of the media (90XiII, 140XiII, and 170XiII only):**

1. Remove the ribbon. Locate the Upper Media Sensor.
2. Remove the Phillips head screw.
3. Lift the Upper Media Sensor assembly and move the sensor and the wire cover to the out-

side half. Carefully pull the wires through the tie wrap. You may need to set aside the sensor wire cover if the adjustment is far to the outside.

4. Replace and tighten the Phillips head screw.
5. Make sure the wires are routed back into the groove of the media sensor bracket.

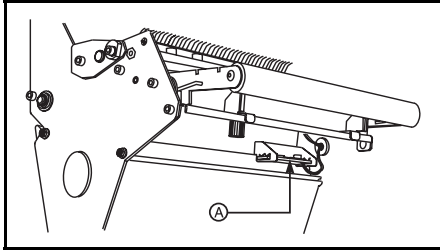

**Figure 10. Lower Media Sensor**

### **Lower Media Sensor Adjustment**

1. Locate the Lower Media Sensor Assembly (Fig. 10-A) under the rear idler roller. (It is a spring clip holding a circuit board.)
2. Slide the sensor until the two brass-colored infrared emitters are under the Upper Media Sensor. Gently pull wires out as needed (wires should have a little slack).

**Note:** If the sensor is being moved inward and a large loop of wire develops, remove the cover from the electronics side of the printer and gently pull the wires through. Clamp the wires so that they do not rub any drive belts.



